

**ISO NEW ENGLAND PLANNING
PROCEDURE NO. 9 APPENDIX B**

**Transmission Owners and ISO-NE
Substation Bus Arrangement
Guideline Working Group Report**

Presented to the NEPOOL Reliability Committee April 4, 2006

**February 23, 2006
Revision 18**

Contents

	<u>Page</u>
INTRODUCTION	2
EXECUTIVE SUMMARY	2
RECOMMENDATIONS	3
RELATIVE BUS ARRANGEMENT COST COMPARISON	6
FIGURE A	7
APPENDIX	8
SUBSTATION DESIGNS CONSIDERED	9 - 21
FIGURES 1-17	22 - 39

New England Standard Substation Bus Arrangement Working Group

Company	Working Group Member
Northeast Utilities	Roger Zaklukiewicz - Chair
Central Maine Power	William Sawyer
Central Maine Power	Mike Smallwood
ISO-NE	David Forrest
National Grid	Dean Latulipe
Northeast Utilities	George Becker
NSTAR	Swapan Dey
United Illuminating	Robert Pellegrini
VELCO	John Fiske
VELCO	Ed McGann

INTRODUCTION

At the June 10, 2005 Transmission Owners and ISO-NE meeting, a Working Group was charged to review possible transmission system substation¹ arrangements and develop a substation bus arrangement guideline for New England. The Working Group's charge was to review all possible transmission grid substation bus arrangements and develop a guideline for substation arrangements that best meets the current and future needs of New England's Transmission Grid.

EXECUTIVE SUMMARY

The Working Group's scope definition statement to develop a standard substation arrangement for bulk power system substations is:

The guideline for substation arrangements must support and promote the reliability of the New England Transmission System. It must incorporate a basic design that is readily expandable and simplifies substation switching to safely isolate facilities and equipment with minimum adverse impact on power flows. It must provide operating flexibility, allow for efficient and effective maintenance of substation equipment, provide for a safe working environment, be cost effective and have the support of the New England Transmission Owners and ISO-NE.

The Working Group recommends that a breaker-and-a-half bus arrangement be adopted as the ultimate design for substations that might become major substations operating at 115 kV or higher. The Working Group further recommends that this design be considered good utility practice in the ISO-NE approval processes for new substations and major modifications to existing substations. However, the Working Group recognizes that in specific cases a different design may also represent good utility practice and thus merit ISO-NE approval as reliable and cost effective.

WORKING GROUP METHODOLOGY

The methodology used to review and evaluate all potential substation arrangements and to select a design was as follows:

1. The design must provide for worker safety. The design shall promote switching sequence consistency and eliminate any possible confusion during switching operations. It must also promote ease of incorporating appropriate working clearances into the design.
2. The design must promote the reliability of the New England Transmission Grid and be supported by the New England Transmission Owners and ISO-NE. The design shall be such that the failure of any switching device in conjunction with a first contingency protective relay operation or a scheduled

¹ The term substation is used throughout the report; however, the term switching station or station may be interchanged if the facility terminates only transmission lines. A substation must have an element which transforms voltages (transformer or autotransformers). A switching station or station interconnects transmission lines only.

outage of any one piece of equipment will not result in the interruption of a critical transmission path.

3. The design must provide operating flexibility and allow for any substation element or piece of electrical equipment to be safely isolated with minimal interruption or risk to the flow of power on the transmission grid.
4. The design must allow for future expandability based on site limitations and land availability. The design shall promote consideration for expansion as part of the initial design scope and equipment installation.
5. The design must promote the efficient and effective maintenance of substation electrical equipment. The design shall promote familiarity with a consistent physical design philosophy and equipment arrangement throughout New England.
6. The design must be cost effective.

RECOMMENDATIONS

The following recommendations are the result of the Working Group's analysis of many possible substation arrangements and their advantages/disadvantages with respect to the methodology outlined above.

General

1. If these guidelines are accepted, then, this Working Group shall draft a formal Planning Procedure to document their application, and submit it to the NEPOOL Reliability Committee.
2. The Working Group recommends that this guideline be considered good utility practice in the ISO-NE approval processes for new substations 115 kV and above and major modifications to existing substations 115 kV and above.
3. The Working Group recommends that ISO-NE recognize that in specific cases a different design may also represent good utility practice and thus may merit approval as reliable and cost effective. These specific cases should be dealt with in the ISO-NE approval process.
4. The Working Group recommends, where practical, that land shall be purchased and equipment shall be arranged to allow for a substation breaker-and-a-half bus configuration when transmission grid expansions dictate. It is not recommended that in all cases a substation initially be built with a breaker-and-a-half bus arrangement, only that the design of the substation provides for expansion to a breaker-and-a-half bus arrangement when the substation might become a major substation.
5. The Working Group recommends the use of air-insulated bus; however, the use of gas-insulated bus should be considered good utility practice when it is

required to provide for a substation arrangement that conforms to the guidelines.

6. The Working Group recommends that, when designing a new substation or doing a major modification to an existing substation, that the Transmission Owner consider the potential for the future termination of transmission elements. For example, if there is vacant space on existing transmission rights-of-way emanating from the substation or the substation is located in an area that is or will be deficient in generation, it may be prudent to plan the substation for additional transmission elements. A discussion of the ultimate number of transmission elements should be included in the application (I.3.9) to ISO-NE.

345 kV Substations

1. For 345-kV substations, the Working Group recommends that the major substation bus arrangement guideline be a "breaker-and-a-half" bus arrangement with space provisions for a series tie breaker in each bay. This requirement only applies to major substations, those that have a reasonable future potential for a total of (4)² or more transmission lines, 345-kV autotransformers, and/or Generator-Step-Up transformers. (see Appendix - Figure A)
2. Where the failure of a tie circuit breaker produces unacceptable operational consequences, a series tie breaker position with no switches between breakers, may be included in the substation design.
3. If a series tie breaker is installed, there is no intention of terminating a transmission element between the two series tie breakers. Doing so would result in a "Breaker-and-a-third" arrangement, which is not the recommended substation bus arrangement. Therefore, the space provision for the series tie breaker should leave sufficient space for the series breaker only, and not for termination of an additional transmission element. No isolating disconnect switches need to be installed between the two series breakers.
4. The following transmission elements should terminate in a designated bay position:
 - a. A transmission line
 - b. An autotransformer interconnecting the 345-kV transmission grid to the 230-kV or 115kV transmission grids³

² The elements in the 345-kV grid tend to be extremely critical to the transmission grid reliability, thus the added reliability of a breaker-and-a-half scheme will be considered good utility practice if 4 or more transmission connections are forecasted.

³ The reason 345-kV autotransformers may not be terminated on the main busses is because of the design problem imposed by breaker failure contingencies for breaker-and-a-half stations containing 3 or more autotransformers. With 2 autotransformers at a station (1 on each main bus), installation of the 3rd is problematic because wherever the 3rd autotransformer is terminated, a breaker failure contingency could result in a tripping of 2 autotransformers. Terminating the autotransformer in individual bays eliminates this potential operating problem.

- c. A "Large Generator" interconnection.
5. Capacitor banks, reactors and load serving transformers (e.g. 345/34.5 kV) may be connected to the main buses in the "breaker-and-a-half" bus arrangement but must have their own 345-kV circuit breaker and their own protective relaying that trips this circuit breaker.

230 and 115 kV Substations

6. For 230 and 115 kV substations, the Working Group recommends that the guideline also be a "breaker-and-a-half" bus arrangement, but with no space provisions for a series tie breaker. This "breaker-and-a-half" requirement only applies to major substations, those that have a reasonable future potential for a total of (4) or more transmission lines, 230 kV autotransformers, and/or Generator-Step-Up transformers.
7. The following transmission elements should terminate in a designated bay position:
 - a. A network (non-radial) transmission line¹
 - b. An autotransformer interconnecting the 230-kV transmission grid to the 115kV transmission grid
 - c. A "Large Generator" interconnection

Note that 115/69-kV autotransformers may be connected to the 115-kV main bus.

8. Capacitor banks and reactors may be connected to the main buses in the "Breaker-and-a-half" bus arrangement but must have their own circuit breaker and their own protective relaying that trips this circuit breaker.
9. Load serving transformers (e.g. 115/13.8 kV) may be connected to the main buses in the "Breaker-and-a-half" bus arrangement. These transformers may be connected to the main bus utilizing a circuit breaker, circuit switcher, or disconnect switch.

69 kV Substations

The working group makes no recommendations for 69-kV substation designs.

¹ The intent of the "non-radial" qualifier is to allow radial lines supplying load serving transformers (e.g., 115/13.8 kV) to be connected directly on the main bus.

RELATIVE BUS ARRANGEMENT COST COMPARISON

The selection of the appropriate station bus arrangement should meet all known or anticipated transmission reliability, operating, and maintenance criteria and future expansion requirements taking into account recognized acceptable contingencies and the associated risks to the Transmission Grid.

To assist in the overall evaluation, Table 1 provides a high level cost comparison of the various substation bus arrangements, should it be necessary to conduct an economic comparison.

Table 1: Station Bus Arrangement Cost Comparison⁵

Bus Arrangement	Approximate Relative Cost Comparison
Single Bus	100%
Sectionalized Bus	122%
Main and Transfer Bus	176%
Ring Bus	156%
Breaker-and-a-half	158%
Double Bus - Double Breaker	214%

The comparison is based on the cost to install a four-circuit low-profile outdoor bus arrangement with power circuit breakers in all circuits. Power transformer and land costs are not included in the cost comparison. In schemes utilizing other protective devices or different circuit quantities, the relative costs may vary from those listed.

⁵ McDonald, John D. Electric Power Substations Engineering CRC Press, New York p. 3-6. 2003

FIGURE A

345KV BREAKER AND A HALF ARRANGEMENT
(ULTIMATE)

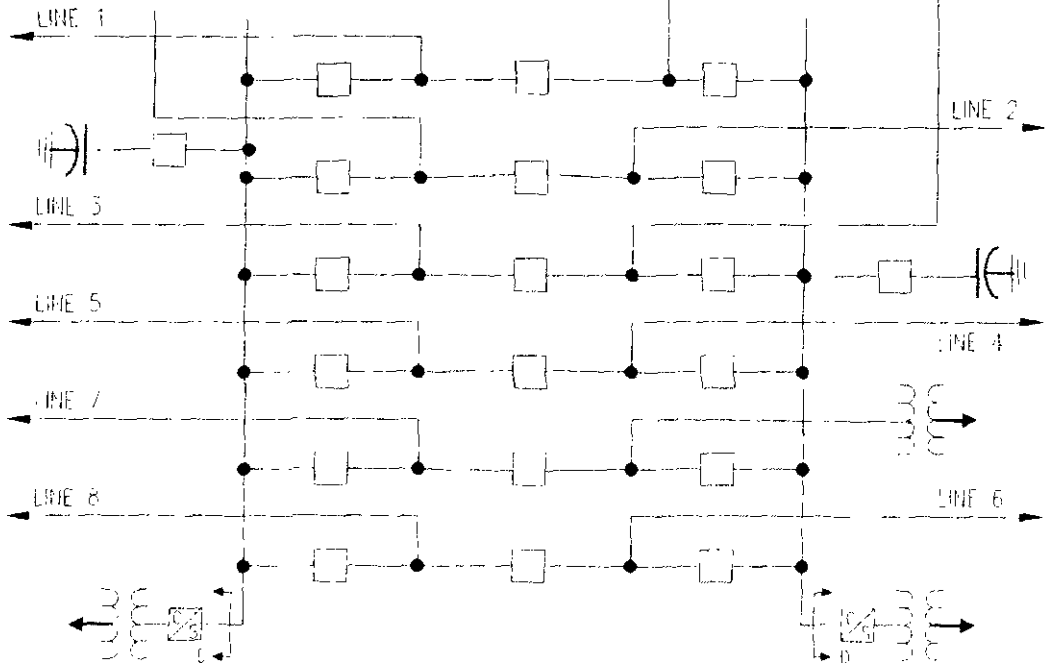
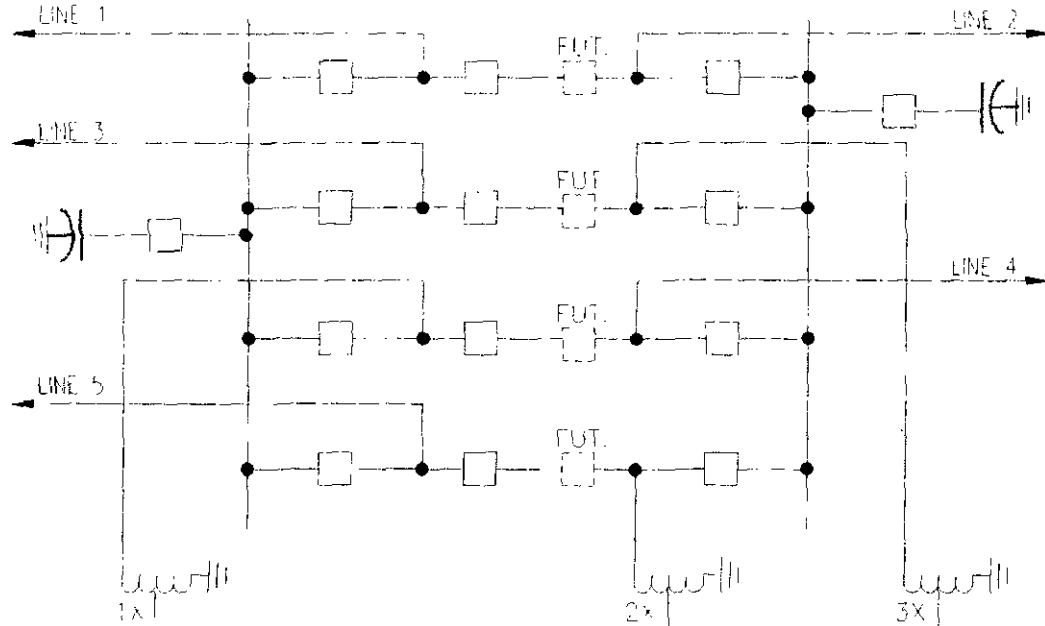

115KV BREAKER AND A HALF ARRANGEMENT
(ULTIMATE)

APPENDIX

SUBSTATION DESIGNS CONSIDERED

TRANSMISSION SUBSTATIONS

In this report, a substation is designated a "Transmission Substation" when it is designed to operate at 115 kV or higher. Since one transmission substation may supply several distribution substations and large loads, reliability of service and flexibility of operation are extremely important. The substation design must permit facilities and electrical equipment to be maintained without having to interrupt other transmission lines, transformers, or equipment necessary to maintain the reliability and integrity of the transmission grid. The employment of multiple buses, circuit breakers, and isolating disconnect switches for switching and isolation provide the required system flexibility. A transmission substation is distinguished from a transmission switching station in that it incorporates a transformer(s) or autotransformer(s) which convert the transmission voltage to either a lower transmission voltage or a distribution voltage.

TRANSMISSION SWITCHING STATIONS

Transmission switching stations do not change system voltage from one level to another and therefore do not contain power transformers. Depending on system voltage, the equipment types and characteristics used in transmission switching stations are identical to those used in transmission substations. The charge to the Working Group did not include the detail engineering design of the substation facilities, electrical equipment, control houses, or its protection and controls capabilities and circuitries. As future ISO-NE/Transmission Owner standards are developed, consideration should be given to the development of such standards to maximize the reliability of the New England transmission grid, minimize operating complexities, maximize flexibility, reduce operating risks, and ensure worker safety.

UNIVERSAL SUBSTATION BUS ARRANGEMENTS

The Working Group conducted a paper search and studied each of the bus arrangements most typically employed for transmission voltages through 765 kV in North America and Western Europe. The Working Group recognized that initially, a transmission substation or switching station might only terminate two transmission lines or terminate into a single transformer/autotransformer. However as the transmission grid expands to accommodate growing load and additional generation, that simple substation/switching station could develop into a full fledged facility having significantly greater importance and requiring far greater flexibility and complexity. Therefore, the recommendations of the Working Group must incorporate a stepped approach for those substations/switching stations that initially are small which permits their expansion in a systematic manner without adversely impacting the reliability of the transmission grid.

The physical size, type, and arrangement of major equipment, such as power transformers, circuit breakers, disconnect switches, dimensions of the property owned by the Transmission Owner, and location of adjacent transmission line rights

of way and private developments may cause variance in the layouts to suit individual requirements. However, the construction of the new or expansion of the existing bus arrangement should not compromise the preferred bus arrangement guideline. The Working Group's scope includes recommending a preferred substation/switching station bus arrangement; this does not include detailed engineering/design of the facility.

SINGLE BUS ARRANGEMENT

A single substation bus arrangement consists of one main bus that is energized at all times and to which all transmission lines and transformers are connected. Each transmission line or transformer is electrically connected to the main bus through a single circuit breaker. This arrangement is the simplest to design and operate, has the least amount of equipment, but provides the least amount of flexibility and system reliability. Figure 1 depicts a possible single bus station arrangement. It is not possible to perform maintenance work on the main bus or sections of a transmission line or transformer directly connected to the bus without taking the entire station out of service. Once in service, the entire station must be de-energized to extend the main bus or to connect an additional transmission line or transformer to the main bus.

Any bus fault or failure of a circuit breaker to operate under fault conditions will result in complete loss of the station. The loss of the entire transmission station could result in transmission line and equipment overloads, unusual power flows throughout the transmission grid. Therefore, in both the planning and real time contingency analysis studies, the loss of a single bus station must be a recognized contingency when the studies are being performed.

On the distribution system, a single bus arrangement is not recommended without providing circuit breaker bypass switching capability that permits circuit breaker maintenance while maintaining circuit operation. Switches are provided that, when closed, parallel two lines to enable one circuit breaker to be removed from service. The other breaker then protects both circuits. Figure 2 illustrates a single bus station with circuit breaker bypass switches. This arrangement, however, results in the possible loss of overcurrent or step distance relay protection coordination for the distribution circuit. A fault occurring on the line with the breaker bypassed could result in the loss of multiple circuits or complete deenergization of the station. Such operating risks are not acceptable on the transmission grid; therefore, a single bus arrangement that employs bypass switch facilities should not be installed on the transmission grid.

Advantages:

1. Lowest cost
2. Small land area required
3. Simple construction
4. Simple in concept and operation
5. Relatively simple for the application of protective relaying

Disadvantages:

1. A single bus arrangement has the lowest reliability
2. Has the least maintenance and operating flexibility
3. Circuit breaker maintenance requires opening the transmission line terminal or removing the transformer from service
4. Highest potential for the loss of the entire station for a bus fault, a fault on any element directly connected to the main bus or for the failure of a circuit breaker
5. Must remove the entire main bus from service to extend the bus or connect an additional transmission line or transformer position
6. Circuit breaker bypass facilities do not provide for circuit protection when bypass facilities are being used

Use of the circuit breaker bypass facilities to support maintenance can compromise or disable some of the protective relay applications and overall relay coordination

Conclusion:

A single bus arrangement is not a suitable design for a major transmission station.

SECTIONALIZED BUS ARRANGEMENT

An extension of the single bus configuration is the single bus station with bus sectionalizing circuit breaker arrangement shown in Figures 3. This arrangement electrically connects two or more single bus schemes with one or more bus sectionalizing circuit breakers. The sectionalizing circuit breaker(s) may be operated normally open or closed, depending on system requirements. In this arrangement, a bus fault or breaker-failure causes only the affected bus section to be removed from service and thus eliminates the risk of the loss of an entire station. Power flows on the transmission grid under normal and emergency conditions must be taken into consideration when locating transmission lines and transformers on each section of the bus such that load is not separated from its source when the sectionalizing circuit breaker is opened. This can be accomplished by positioning interrelated transmission lines on different bus sections to minimize or eliminate entirely the possibility of abnormally low voltage or overloaded transmission line conditions.

A main bus fault or breaker-failure condition can be isolated to the faulted bus section without interrupting the entire station. The adverse impact of a bus fault or breaker-failure on the transmission grid is appreciably less when a sectionalizing circuit breaker is installed between the buses due to the increased flexibility of this bus arrangement.

Advantages:

1. Greater operating flexibility than a single bus arrangement
2. Higher reliability than a single bus arrangement
3. Ability to isolate bus sections for maintenance

4. Simple construction
5. Simple in concept and operation
6. Loss of only part of the station following a bus fault or breaker-failure condition
7. Relatively simple for the application of protective relaying

Disadvantages:

1. A sectionalized bus arrangement has a higher cost than a single bus arrangement
2. Additional circuit breakers are required for sectionalizing
3. Sectionalizing may cause isolation of source circuits from load circuits for a bus fault, a fault on any element directly connected to a bus, or for the failure of a circuit breaker.
4. Circuit breaker maintenance requires opening the transmission line terminal or removing the transformer from service
5. Must remove a bus section from service to extend the bus or connect an additional transmission line or transformer position to that bus section
6. Potential for the loss of the entire station for a bus fault with the failure of the bus tie circuit breaker

Conclusion:

A sectionalize bus arrangement is not a suitable design for a major transmission station.

MAIN AND TRANSFER BUS ARRANGEMENT

A main and transfer bus arrangement consists of two independent buses, one of which, the main bus, is normally energized. During normal operations, all transmission lines and transformers are electrically connected to the main bus similar to that of a single bus station arrangement. When it is necessary to remove a circuit breaker from service for maintenance or repair, it is possible to switch the transmission line or transformer to the transfer bus such that there is no loss of service. The isolation switches associated with the bus tie circuit breaker are closed, the bus tie circuit breaker is closed energizing the transfer bus, then the bypass switch for the circuit breaker to be isolated is closed paralleling the transmission line or transformer to the main and transfer buses. The bypassed circuit breaker and its isolation switches are then opened to remove the circuit breaker from service. The transmission line or transformer is then protected by the protective relaying package associated with the bus tie circuit breaker.

Figure 4 illustrates simplified main and transfer bus station arrangements. As with the single bus arrangement it is possible to incorporate one or more sectionalizing circuit breakers to provide additional operating flexibility and reliability. Figure 5 illustrates a main and transfer bus arrangement station incorporating a sectionalizing circuit breaker which minimizes the number of transmission lines and transformers on each bus section. With this arrangement, there is appreciably less

risk that a bus fault or breaker-failure condition would result in the loss of the entire station. In addition, it's possible to incorporate more tailored protection packages for each bus tie circuit breaker.

Advantages:

1. Ability to perform circuit breaker maintenance while maintaining transmission line and transformer service
2. Reasonable in cost
3. Fairly small land area
4. Where the transmission lines and transformers can be placed on the transfer bus the main bus can be readily expanded without service interruption

Disadvantages:

1. An additional circuit breaker is required for the bus tie position
2. Since the bus tie breaker has to be able to be substituted for any transmission line or transformer circuit breaker, its associated protective relaying must have the functional capability of the protective relaying for each element connected to the bus and relay settings must be changed for each use of the transfer circuit breaker.
3. Failure of a circuit breaker or a bus fault causes loss of the entire substation
4. Somewhat complicated switching is required to remove a circuit breaker from service for maintenance
5. May have to remove some transmission lines or transformers from service to extend the bus or connect an additional transmission line or transformer position to that bus section
6. Loss of the entire station for a bus fault, a fault on any element directly connected to the main bus or for the failure of a circuit breaker

Conclusion:

A main and transfer bus arrangement is not a suitable design for a major transmission station.

RING - BUS ARRANGEMENT

The ring-bus station arrangement is one of the simplest and most commonly constructed transmission bus arrangements in existence. In a ring bus arrangement, circuit breakers are placed between transmission lines or transformer position as illustrated in Figure 6; there are always two circuit breakers associated with each transmission line or transformer position. Since each circuit breaker in the ring is shared, it is possible to perform maintenance on each circuit breaker without impacting the operation of the transmission line or transformer position on either side of the circuit breaker.

Bus differential protection packages are not required because there is no designated main or transfer bus in this arrangement. The section of the ring between circuit breakers is always protected by the protective relaying package of each transmission line or transformer position. The philosophy and application of the protection and controls circuitries for either the transmission line or transformer position are similar lending them to an ease of understanding of how each protective relay package works. The required switching to safely isolate each transmission line or transformer position is also similar which simplifies operations and should result in improved system reliability.

Ring buses should be limited in total to four to six transmission line and transformer positions in order to maximize the flexibility and reliability of this bus arrangement. This limitation is driven by the two factors. Whenever maintenance is being performed on a circuit breaker or one of its two isolating disconnect switches one must open the bus which interrupts the normal flow of power around the ring bus. In certain operating circumstances, power flows in sections of the bus could exceed the current ratings of circuit breakers, disconnect switches, or other hardware. More importantly, should a fault occur on a transmission line or transformer connected to the bus, it is possible that source transmission lines could be isolated from transmission lines and transformer positions which are serving load. Whenever the ring bus must be opened to perform maintenance or during shorter periods to perform switching, the reliability of the ring bus arrangement decreases to that of the single bus arrangement with sectionalizing circuit breakers.

When system studies indicate that system reliability degrades significantly when two transmission lines or one transmission line and one transformer are simultaneously removed from service they should not share a common circuit breaker. The most common case occurs whenever two transmission lines are located on a common transmission structure, determining where best to connect each transmission line to the ring bus. If the transmission lines are connected in adjacent positions both transmission lines will be lost for a breaker-failure condition. If they do not share adjacent positions in the ring, there is the possibility that the bus will be split whenever a double circuit transmission line fault occurs. The probability of each contingency occurring must be studied and incorporated in the decision of where to locate each transmission line or transformer on the ring bus.

Once constructed and placed in service, it is difficult to expand the ring bus unless planned for in the engineering/design phase. Of concern in New England are the multiple transmission element outages that can occur following a breaker-failure contingency. If it is unacceptable to have adjacent positions of a ring bus out of service simultaneously, a possible solution is to install two circuit breakers in series as illustrated in Figure 7. In this configuration a breaker-failure of the circuit breakers associated with either Line 1 or Line 2 nearest transformer T1, would not result in the simultaneous loss of transformer T1. It is not possible to predict how the transmission grid will develop; therefore, if ring-bus stations are initially installed it may be prudent to allow for the addition of a series circuit breaker on either side of each circuit breaker. A second alternative would be to design the bus so that it can be easily expandable to a breaker-and-a-half arrangement as illustrated in Figure 8.

Advantages:

1. Flexible operation
2. Ease of understanding zones of protection, controls, and personal safety
3. High reliability
4. Isolation of circuit breakers for maintenance without disrupting transmission line or transformer operation
5. Double feed to each transmission line or transformer position
6. No main buses
7. Expandable to breaker-and-a-half bus arrangement
8. Lowest cost bus design with similar reliability and flexibility

Disadvantages:

1. Ring bus will split for faults on two transmission lines on a common transmission structure or for a fault on a transmission line or transformer position during breaker maintenance to leave possibly undesirable circuit combinations (supply/load) on the remaining bus sections.
2. Each circuit has to have its own potential source for protective relaying.
3. This configuration is usually limited to four circuit positions, although larger rings are in service. A 6-position ring bus is usually considered as a maximum limit for the number of terminals in a ring bus.
4. The protective relaying and controls schemes are more involved since each circuit breaker has to respond to faults on two circuits.
5. Automatic reclose schemes may be more complex since each circuit breaker may have different control modes depending upon which transmission line or transformer position trips.
6. Difficult to expand unless initial design incorporates that flexibility

Conclusion:

A ring bus arrangement is not a suitable design for a major transmission station. However a ring bus that can be expanded into a breaker-and-a-half bus arrangement would be suitable for the initial design of a substation that may become a major substation in the future.

BREAKER - AND - A - HALF BUS ARRANGEMENT

The breaker-and-a-half bus arrangement is relatively simple and consists of two main buses, each normally energized. Between each of the main buses are similarly arranged "bays" of three circuit breakers configured such that the two transmission lines or combination transmission line and transformer position share the center circuit breaker as illustrated in Figure 9. Each transmission line or transformer position shares the common center circuit breaker, so there are one-and-a-half

circuit breakers per position; therefore, the designation a "breaker-and-a-half" bus arrangement.

The breaker-and-a-half bus arrangement is the most prominently used transmission substation configuration in North America. It is more reliable than a ring-bus arrangement and provides appreciably more operating flexibility.

Similar to a ring-bus configuration, each transmission line or transformer position can be served from two directions. It is possible to maintain one of the two circuit breakers associated with each transmission line or transformer position without impacting power flow. Since each of the bays connects to a main bus, the breaker-and-a-half bus arrangement does not have the operating restrictions of a ring bus arrangement when work is being performed on a circuit breaker as the main buses are designed to carry appreciably greater current flows than the circuit breakers and buses in any given bay. Similar to a ring-bus configuration, one should not electrically connect two transmission lines or a transmission line and a transformer that cannot be simultaneous out of service to adjacent positions in a given bay. A breaker-failure of the shared circuit breaker would require the interruption of power flow to both positions should such a contingency occur. Additionally, faults on either of the main buses cause no circuit interruptions

The breaker-and-a-half bus arrangement has little advantage over the ring bus arrangement when there are in total fewer than four transmission lines or transformer station positions. Breaker-and-a-half stations are more expensive to construct than ring bus stations; therefore, if the number of positions is to remain limited well into the future, designing and constructing a ring bus station would be the more cost effective solution. The breaker-and-a-half arrangement should be used for stations where there a large number of transmission lines and transformer positions terminating at that location.

At those locations where the number of transmission right of way corridors is limited and a majority of the transmission lines must exit on a single transmission right of way a variation of the basic breaker-and-a-half station may be preferred. Figure 10, illustrates such an arrangement. The folded breaker-and-a-half station arrangement is electrically identical to the bus arrangement in Figure 9; however, it is designed to assist transmission line engineers maximize the number of transmission lines that can exit the station where limited right of ways exist.

As with ring-bus stations, once a breaker-and-a-half station is constructed and placed in service, it is difficult to place a second breaker in series with a circuit breaker unless provisions are incorporated during the initial engineering design of the station. Transmission grid operating conditions may not allow the simultaneous loss of two transmission lines or the combination of a transmission line and a transformer position following a breaker-failure. In a breaker-and-a-half station arrangement, such design provisions only need to be incorporated for the center or shared circuit breaker position. If one of the circuit breakers directly connected to either main bus position were to fail, only the transmission line or transformer position directly connected to the position would remain impacted. Figure 11 illustrates possible connections of two circuit breakers in the center or shared circuit breaker position.

Figures 12 and 12A illustrate an autotransformer electrically connected to one of the main buses through a disconnect switch. Should there be a fault in the autotransformer, it would be necessary to trip all circuit breakers directly connected to that main bus and the transformer's low voltage bus circuit breaker(s) to isolate the fault from the transmission grid. The ISO-NE standard should not allow a Transmission Owner to electrically connect any circuit element to the main bus without a circuit breaker or a circuit switcher. The reliability of the entire station decreases when direct connection of a capacitor bank, a transformer or a transmission line to the main bus is permitted. Operating flexibility is also negatively impacted requiring the main bus to remain out of service anytime work must be performed on the disconnect switch or circuit switcher. The cost to install the additional circuit breaker is not trivial; however, the potential negative impacts to the breaker-and-a-half station outweigh those added costs. It is the working group's recommendation that such electrical connections not be permitted.

Advantages:

1. Greater operating flexibility than a ring bus
2. Higher reliability than a ring bus
3. Ability to isolate either main bus for maintenance without disrupting service
4. Can isolate any circuit breaker for maintenance without disrupting service to the transmission line or transformer
5. Double feed to each transmission line or transformer
6. Bus fault does not interrupt service to any transmission line or transformer
7. All switching performed with circuit breakers
8. Maintenance of circuit breaker or isolating disconnect switch does not open the bus should a fault occur during the maintenance period
9. Appreciably less risk of isolating Transmission grid sources from the load
10. Easy to add a double bus – double breaker bay

Disadvantages:

1. Greater costs than a ring bus station arrangement
2. One-and-a-half circuit breakers are required per circuit
3. Utilization of different protective relaying and control philosophies within the station
4. The protective relaying and control schemes are more involved and complex since the center or common circuit breaker has to respond to faults on two circuits
5. Automatic reclose schemes associated with the center or common circuit breakers may be more complex since each circuit breaker may have different control modes depending upon which transmission line or transformer position trips
6. Each transmission line requires its own potential source for relaying
7. Must remove one of the bus sections from service to extend the bus or electrically connect another bay to the station
8. Difficult to add a second circuit breaker in series with the center or common circuit breaker unless space is provided in the original station design

9. A bus fault requires the tripping of one breaker per bay, therefore increasing the potential for a breaker-failure contingency to occur if there are many bays

Conclusion:

A breaker-and-a half bus arrangement is a suitable design for a major transmission station.

BREAKER - AND - A - THIRD BUS ARRANGEMENT

The breaker-and-a-third utilizes four circuit breakers between its main buses and has two common circuit breakers. The reliability of a breaker and third bay is lower than the bay of a breaker-and-a-half arrangement; however, it is better than that of a ring bus station. A breaker-failure of either of the shared circuit breakers will result in the loss of two transmission facilities (line or transformer) similar to that in a breaker-and-a-half station. The difference being that with a breaker-and-a-third bus arrangement the probability that this contingency might occur is twice as great. Figure 13 illustrates a breaker-and-a-third bus arrangement.

Advantages:

1. Greater operating flexibility than a ring bus
2. Higher reliability than a ring bus
3. Ability to isolate either main bus for maintenance without disrupting service
4. Can isolate any circuit breaker for maintenance without disrupting service to the transmission line or transformer
5. Double feed to each transmission line or transformer
6. Bus fault does not interrupt service to any transmission line or transformer
7. All switching performed with circuit breakers
8. Maintenance of circuit breaker or isolating disconnect switch does not open the bus should a fault occur during the maintenance period
9. Appreciably less risk of isolating Transmission grid sources from the load

Disadvantages:

1. Greater costs than a ring bus station arrangement
2. One-and-a-third circuit breakers are required per circuit
3. Utilization of different protective relaying and control philosophies within the station
4. The protective relaying and control schemes are more involved and complex since the two center or common circuit breakers have to respond to faults on two circuits
5. Automatic reclosing schemes associated with the two center or common circuit breakers may be more complex since each circuit breaker may have different control modes depending upon which transmission line or transformer position trips
6. Each transmission line requires its own potential source for relaying

7. Must remove one of the bus sections from service to extend the bus or electrically connect another bay to the station
8. Difficult to add a second circuit breaker in series with either of the center or common circuit breakers unless space is provided in the original station design
9. The risk of a failure of a shared breaker may be twice as great as that for that of a breaker-and-a-half bus arrangement.
10. A bus fault requires the tripping of one breaker per bay, therefore increasing the potential for a breaker-failure contingency to occur if there are many bays

Conclusion:

A breaker-and-a-third bus arrangement is a suitable design for a major transmission station. In cases where a breaker-and-a-half arrangement is not feasible, either physically, environmentally, or economically, a breaker-and-a-third bus arrangement may be an acceptable alternative.

DOUBLE BUS – DOUBLE BREAKER ARRANGEMENT

The double bus - double breaker bus arrangement is employed where ultimate station reliability is required. This bus arrangement provides the greatest reliability and flexibility and has the greatest cost. The two main buses are normally energized; in each designated bay between the main buses are two circuit breakers and, between the circuit breakers is a transmission line or transformer position as illustrated in Figure 15.

In the double bus - double breaker arrangement, any circuit breaker can be removed from service without interrupting the power flows on any transmission line, transformer position or the main bus. A fault on either main bus has no direct impact on the power flowing on any transmission line or transformer position. Equally important, a breaker-failure contingency results in the loss of only one transmission line or transformer position.

Protection and control schemes for each transmission line and transformer position will be similar minimizing the complexity of the schemes associated with the center or common breaker of a breaker-and-a-half station. The required switching and tagging for each transmission line or transformer position will be similar, which should make it easier for the workers to understand and switch.

Use of the double bus - double breaker has traditionally been limited to large generating stations because of its higher cost. The additional reliability afforded by this arrangement over the breaker-and-a-half scheme usually cannot be justified for conventional transmission stations. Occasionally, one bay of a breaker-and-a-half arrangement is used as a double bus - double breaker arrangement for a generator lead, critical transmission line, or large autotransformer, that requires access to either main bus.

Advantages:

1. Greatest operation flexibility

2. Very high reliability
3. Ability to isolate either main bus for maintenance without disrupting service
4. Can isolate any circuit breaker for maintenance without disrupting transmission line or transformer operation
5. Double feed to each transmission line or transformer position
6. Bus fault does not interruption service to any transmission line or transformer
7. Loss of only one transmission line or transformer position following a breaker-failure contingency
8. No need to place two circuit breakers in series to negate the negative impacts of a breaker-failure contingency
9. Maintenance of circuit breaker or isolating disconnect switch does not open the bus should a fault occur during the maintenance period
10. All switching performed with circuit breakers
11. Least risk of isolating Transmission grid sources from load
12. Similar protective relaying and control schemes for each bay
13. Switching for each transmission line or transformer position is similar

Disadvantages:

1. This bus configuration has the highest cost
2. Two circuit breakers are required for each transmission line or transformer position
3. Utilization of different protective relaying and control philosophies within the station
4. Each transmission line or transformer position requires its own potential source for relaying
5. Must remove both of the main buses from service to extend the bus or electrically connect another bus to the station
6. Requires more land than a breaker-and-a-half station
7. A bus fault requires the tripping of one circuit breaker per bay, therefore increases the potential for a breaker-failure contingency to occur if there are many bays

Conclusion:

Under normal circumstances, a double-bus-double-breaker bus arrangement is too costly a design to be considered good utility practice for a major transmission substation. However there may be specific cases where the use of this bus arrangement may be prudent, to address real estate constraints or the need for greater reliability.

FIGURES 1-17

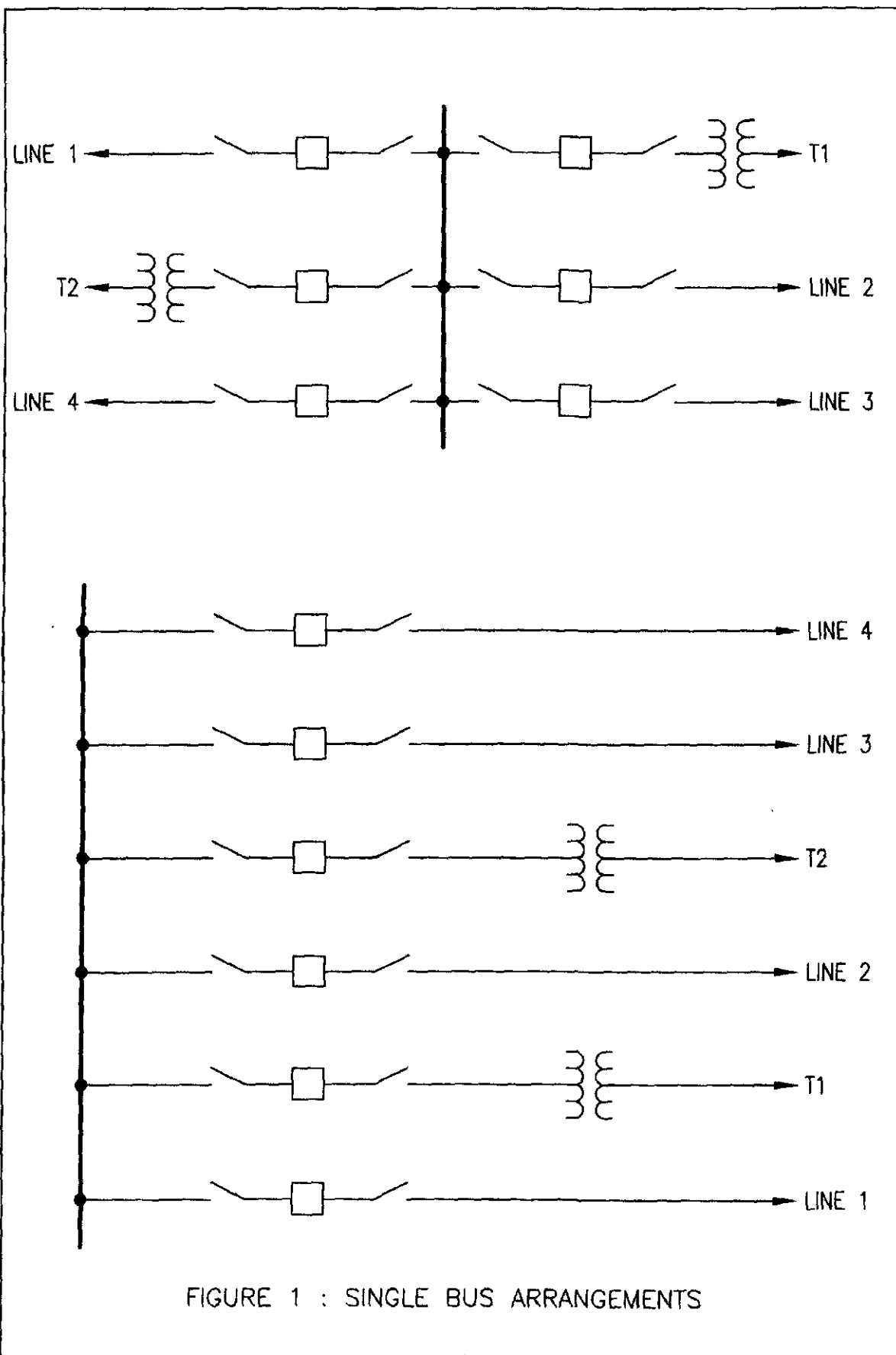

FIGURE 1 : SINGLE BUS ARRANGEMENTS

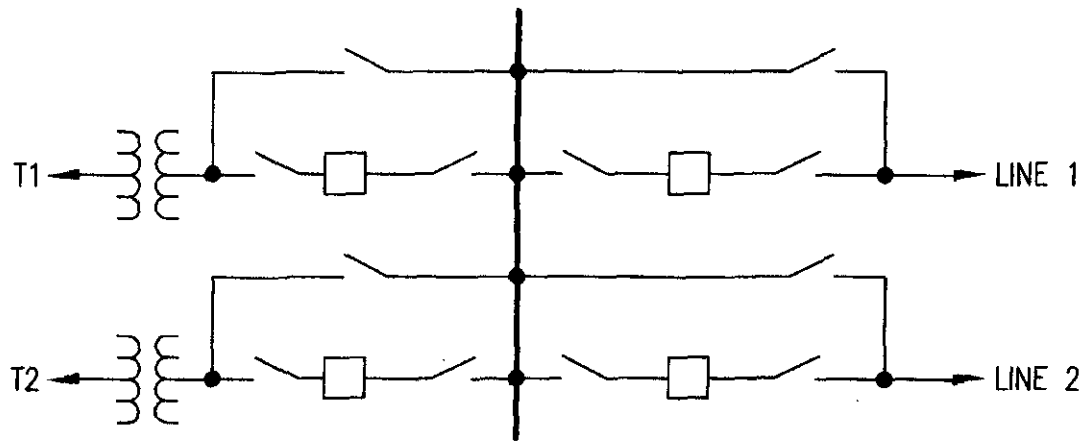

FIGURE 2 : SINGLE BUS ARRANGEMENT
WITH BREAKER BYPASS
SWITCHES

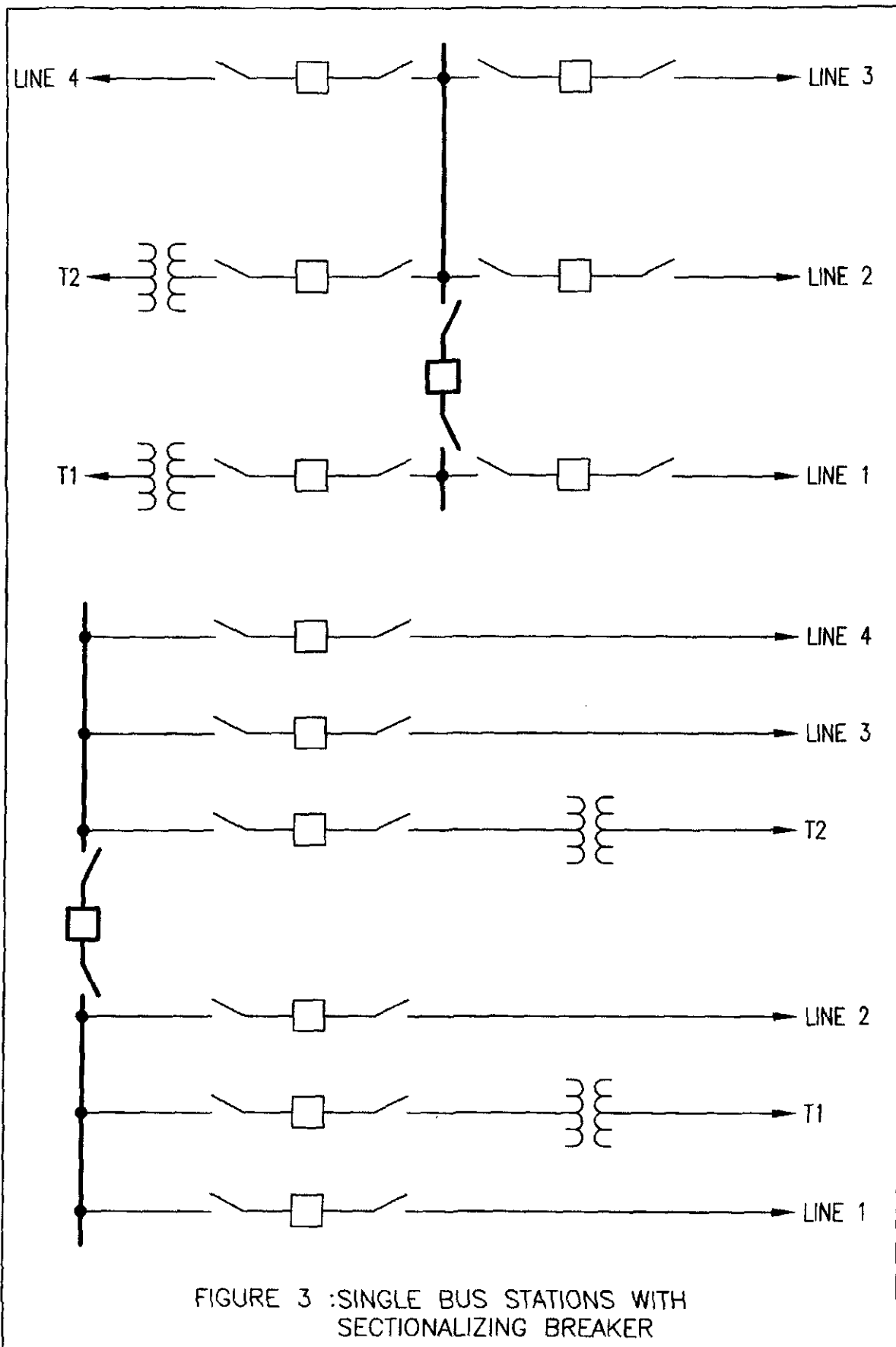

FIGURE 3 :SINGLE BUS STATIONS WITH SECTIONALIZING BREAKER

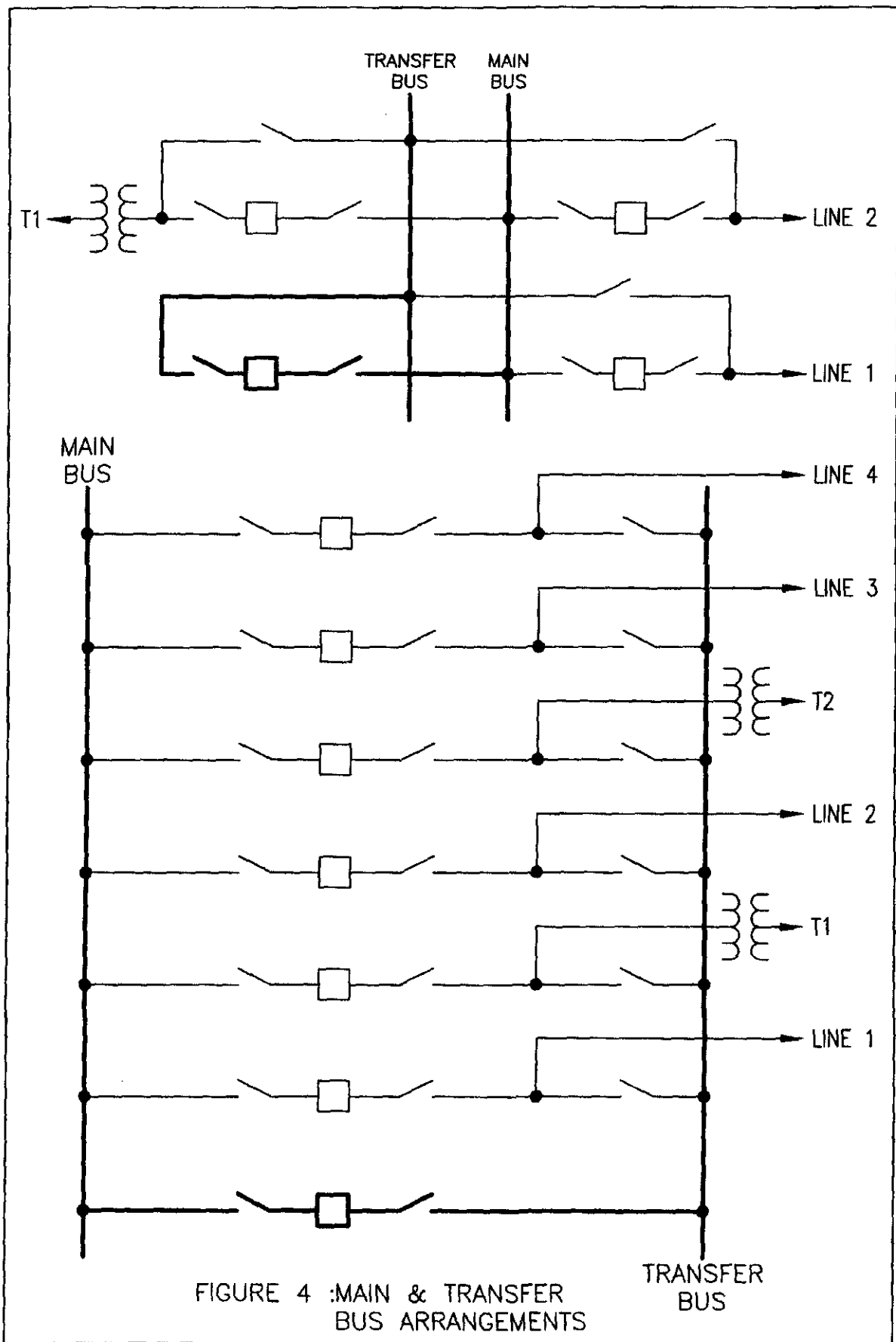

FIGURE 4 :MAIN & TRANSFER BUS ARRANGEMENTS

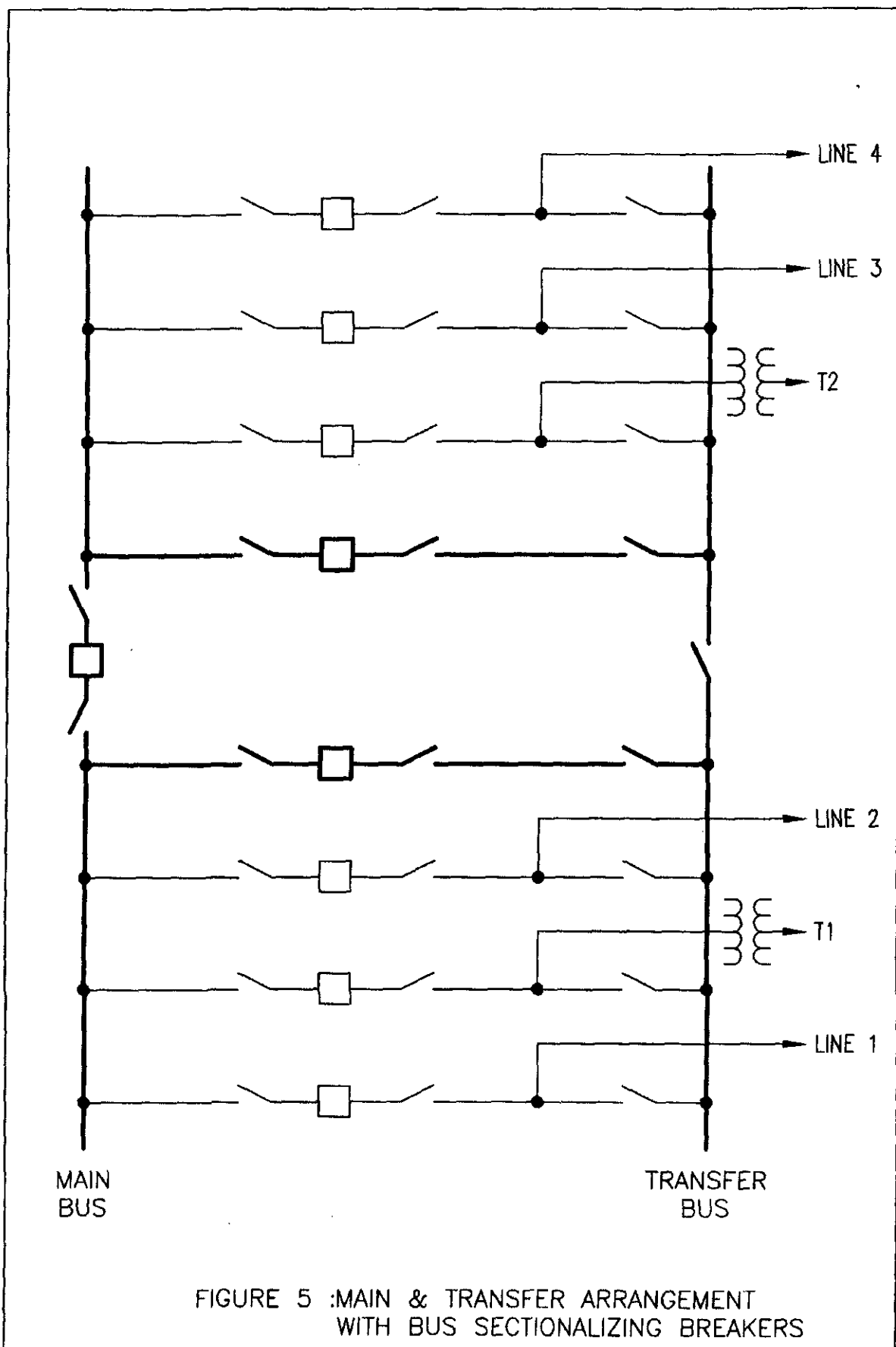

FIGURE 5 :MAIN & TRANSFER ARRANGEMENT WITH BUS SECTIONALIZING BREAKERS

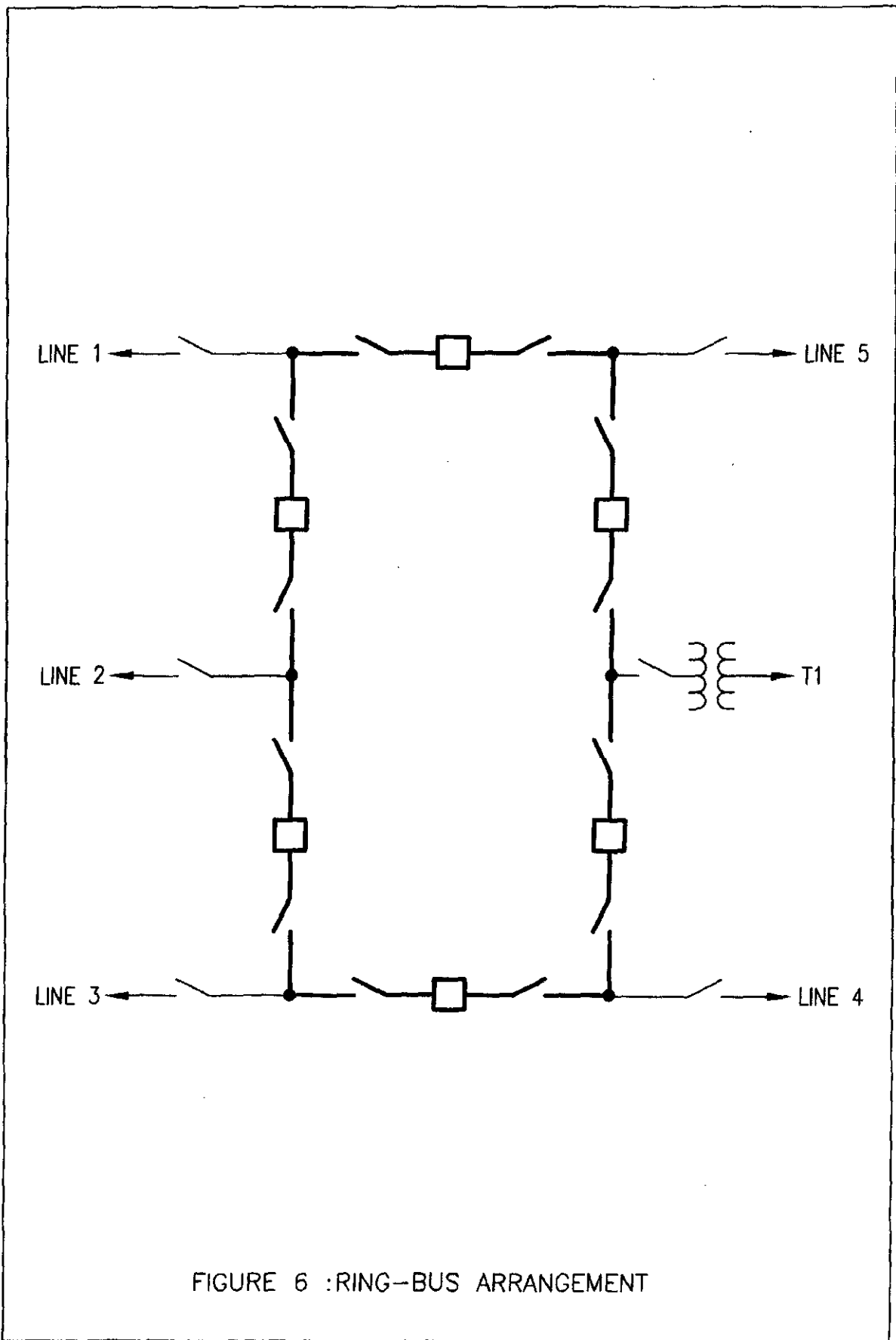

FIGURE 6 :RING-BUS ARRANGEMENT

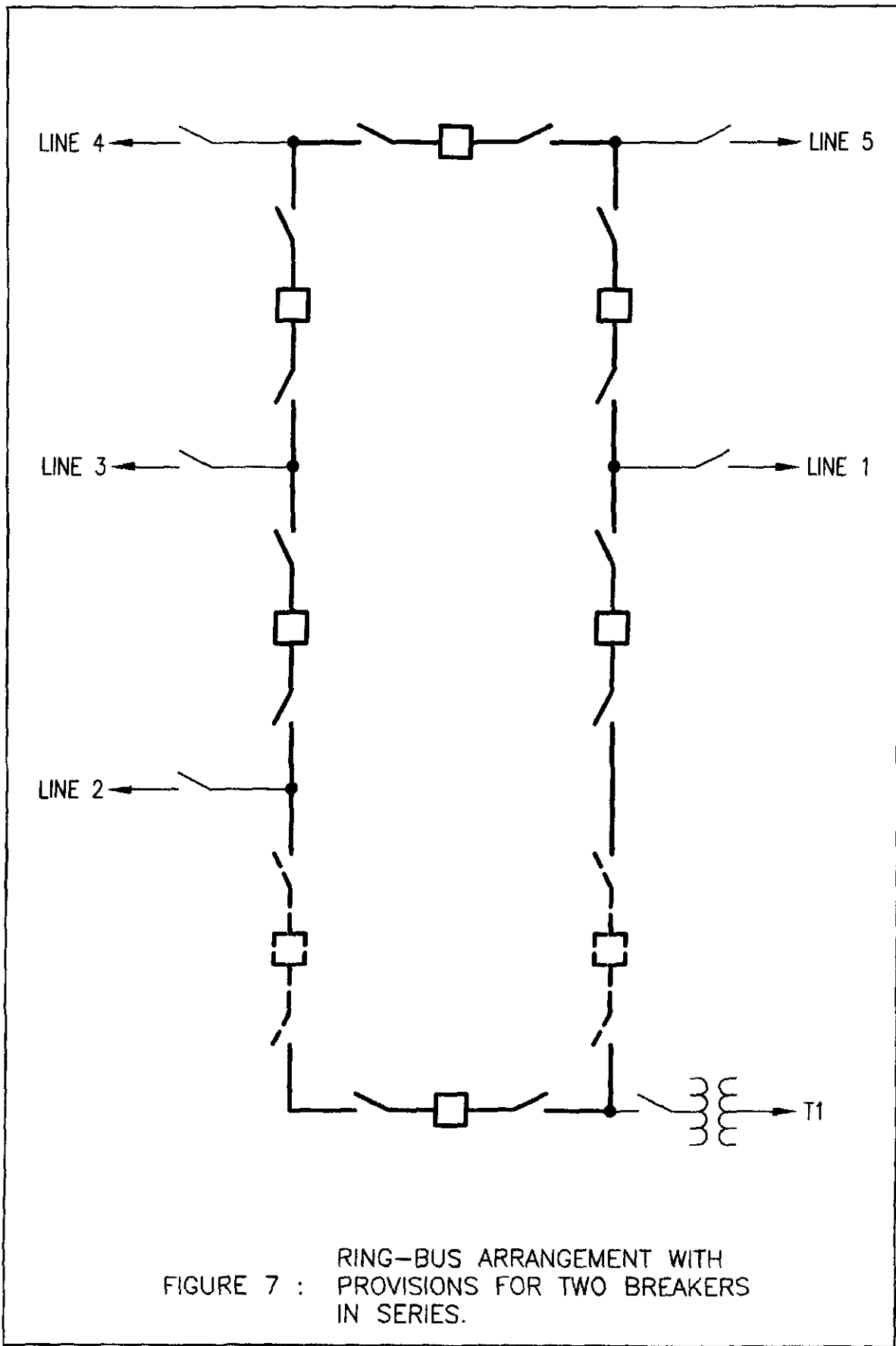

FIGURE 7 : RING-BUS ARRANGEMENT WITH PROVISIONS FOR TWO BREAKERS IN SERIES.

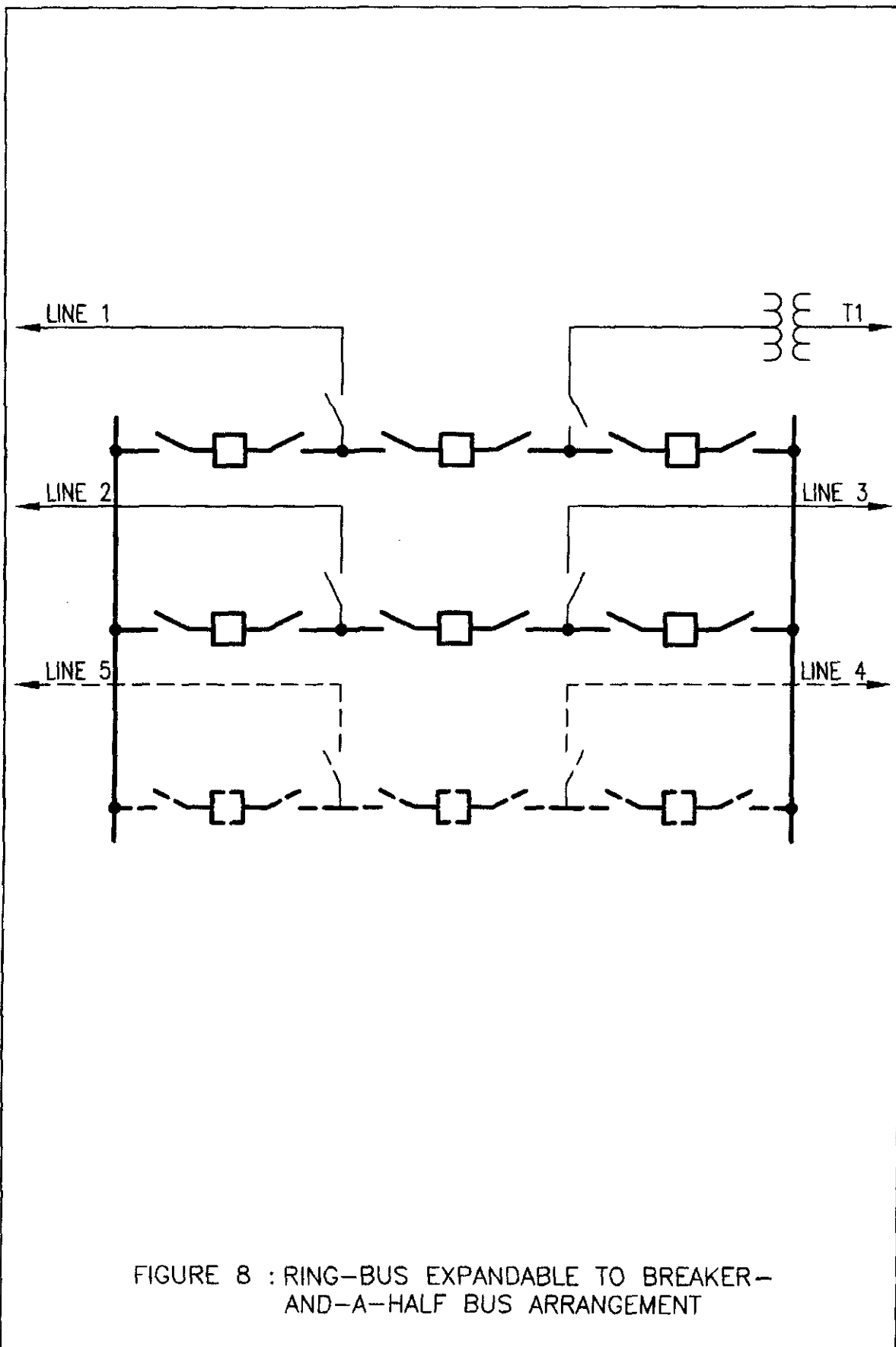

FIGURE 8 : RING-BUS EXPANDABLE TO BREAKER-
AND-A-HALF BUS ARRANGEMENT

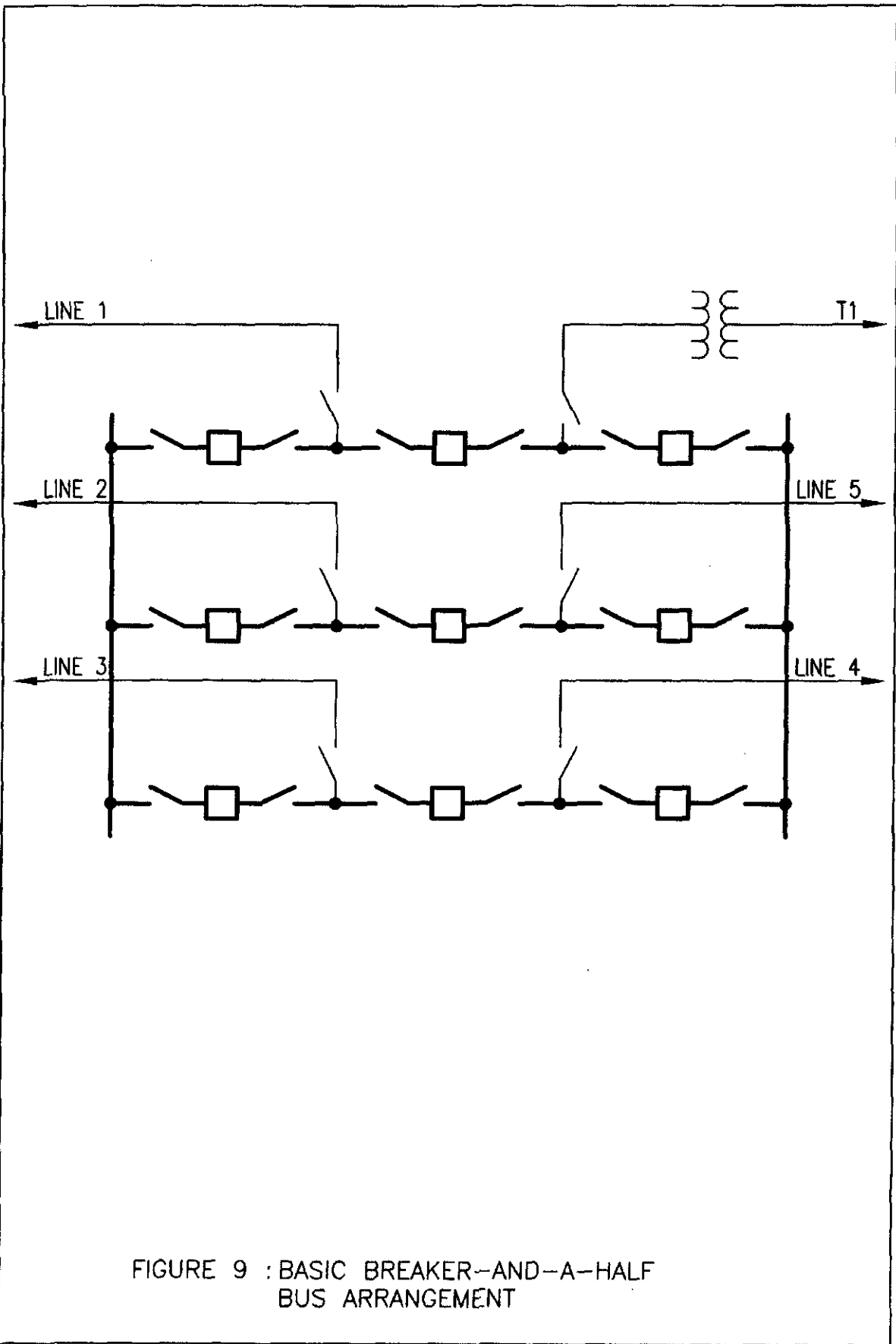

FIGURE 9 : BASIC BREAKER-AND-A-HALF
BUS ARRANGEMENT

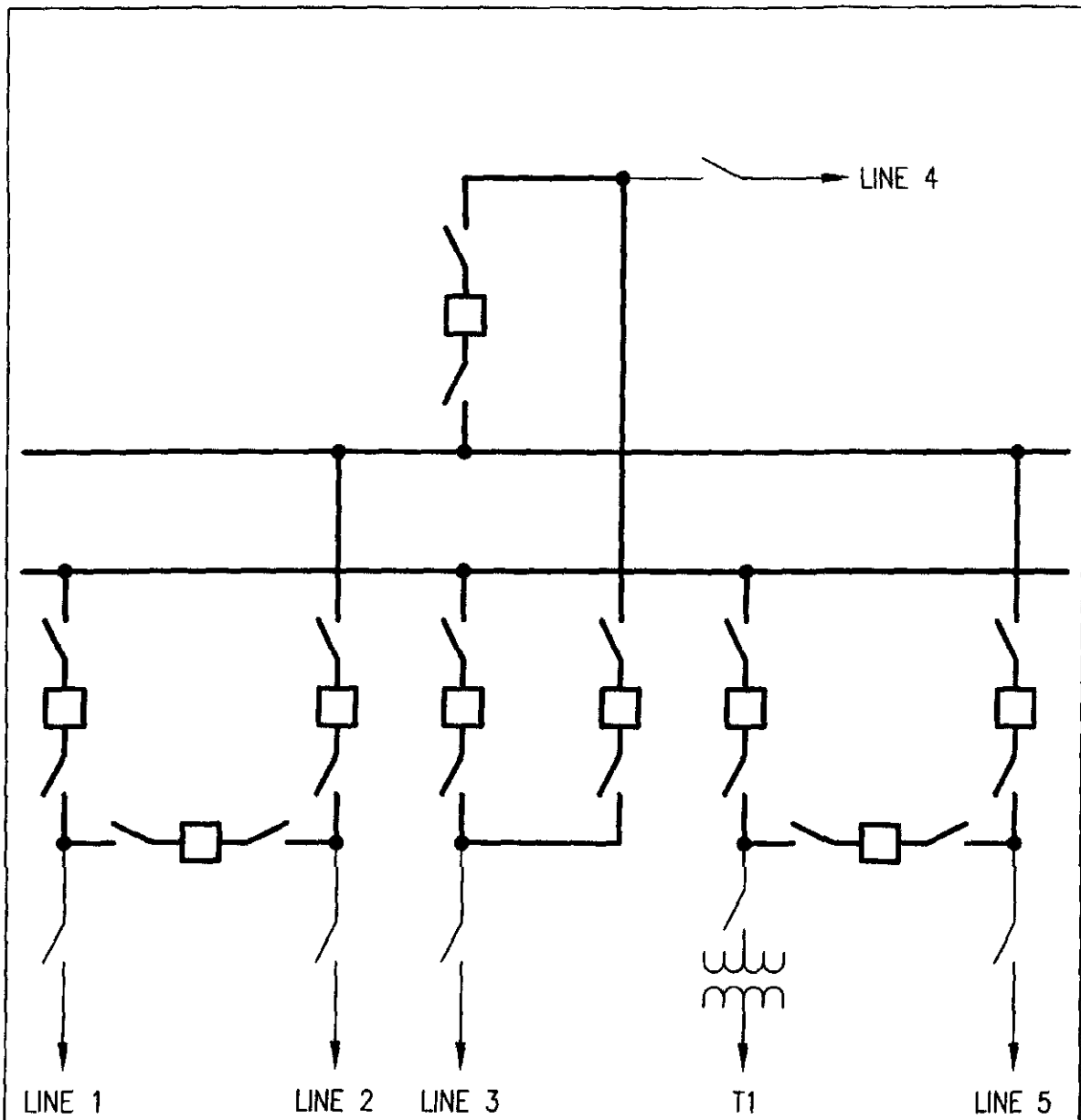

FIGURE 10 : FOLDED BREAKER-AND-A-HALF BUS ARRANGEMENT

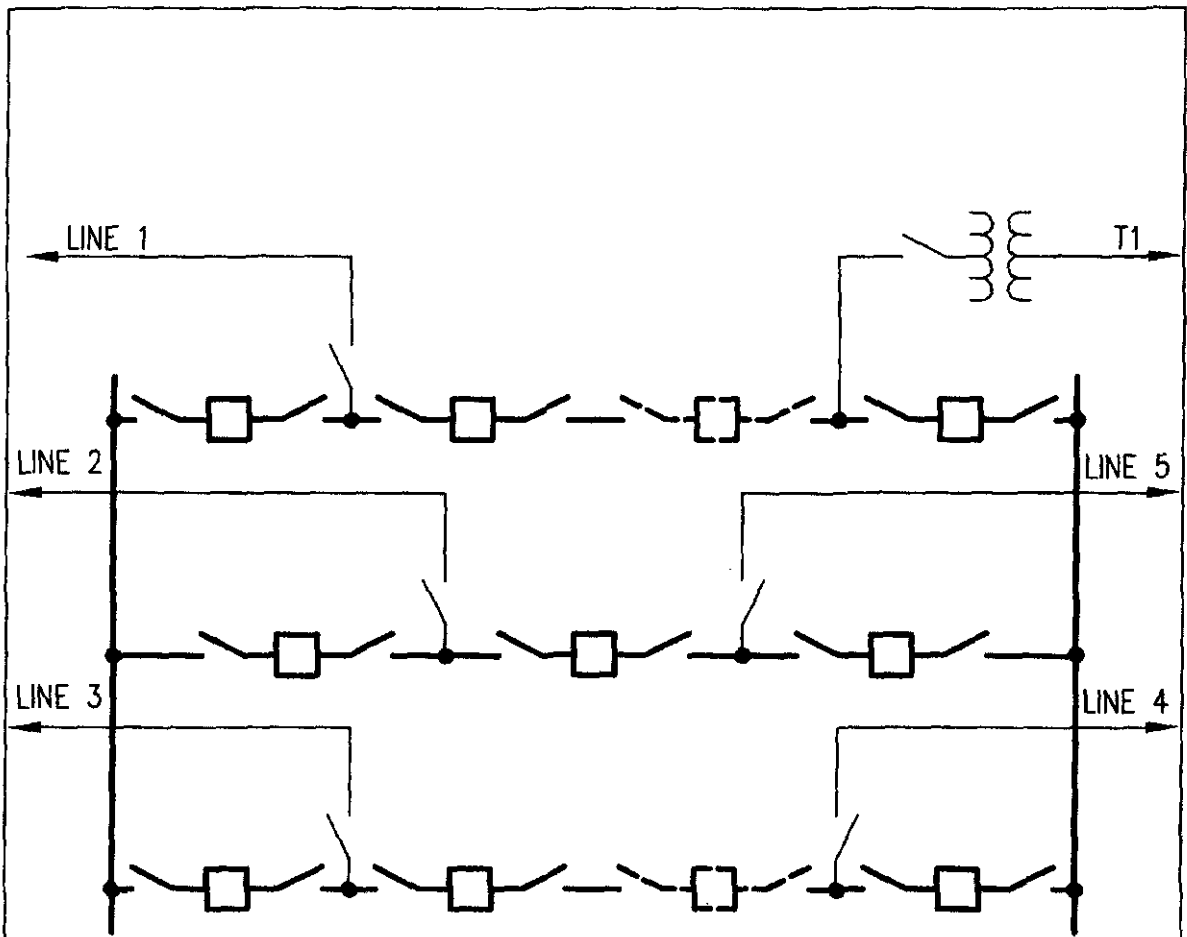

FIGURE 11 : BREAKER-AND-A-HALF BUS ARRANGEMENT
WITH PROVISIONS FOR TWO BREAKERS IN SERIES

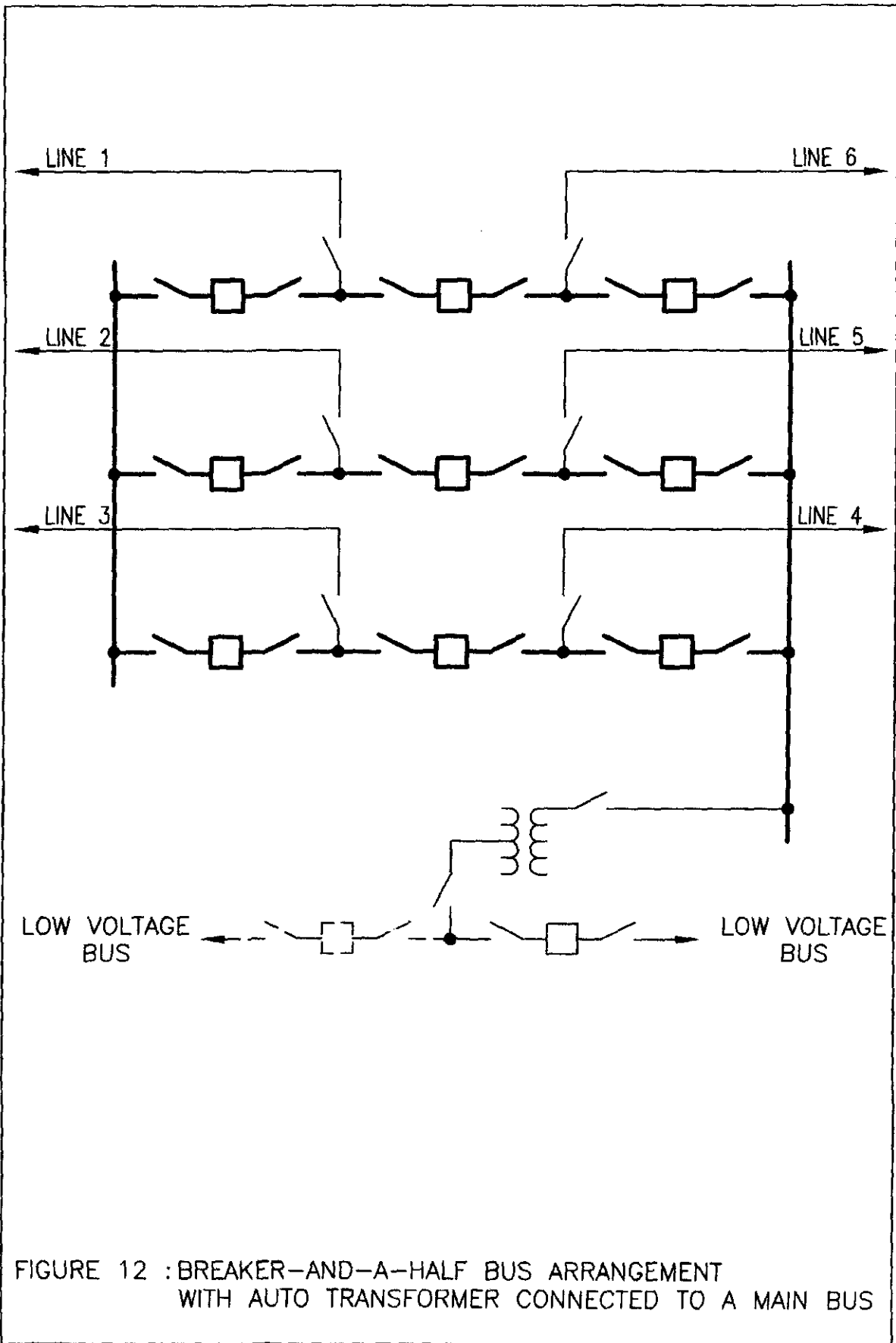

FIGURE 12 : BREAKER-AND-A-HALF BUS ARRANGEMENT
WITH AUTO TRANSFORMER CONNECTED TO A MAIN BUS

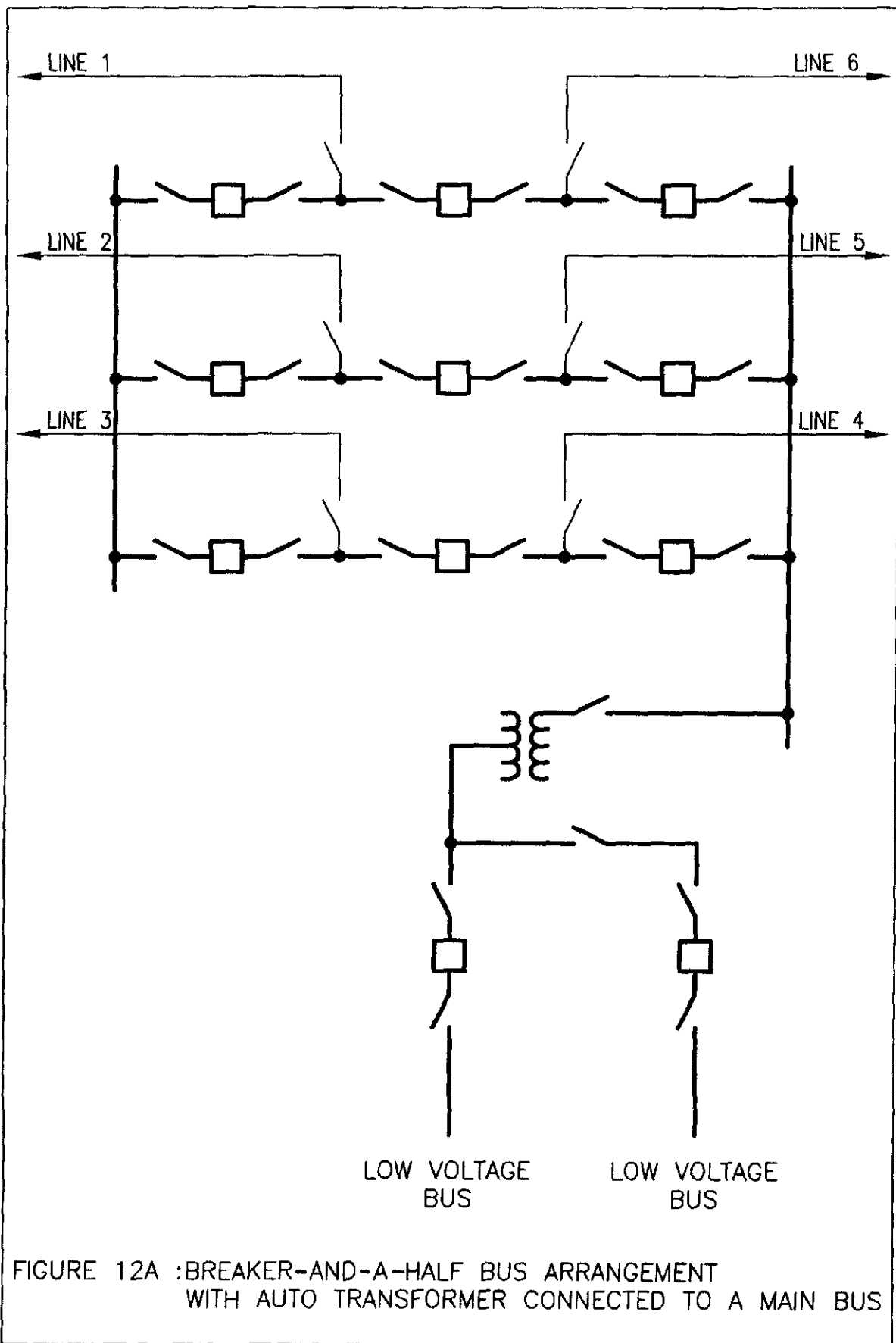

FIGURE 12A :BREAKER-AND-A-HALF BUS ARRANGEMENT
WITH AUTO TRANSFORMER CONNECTED TO A MAIN BUS

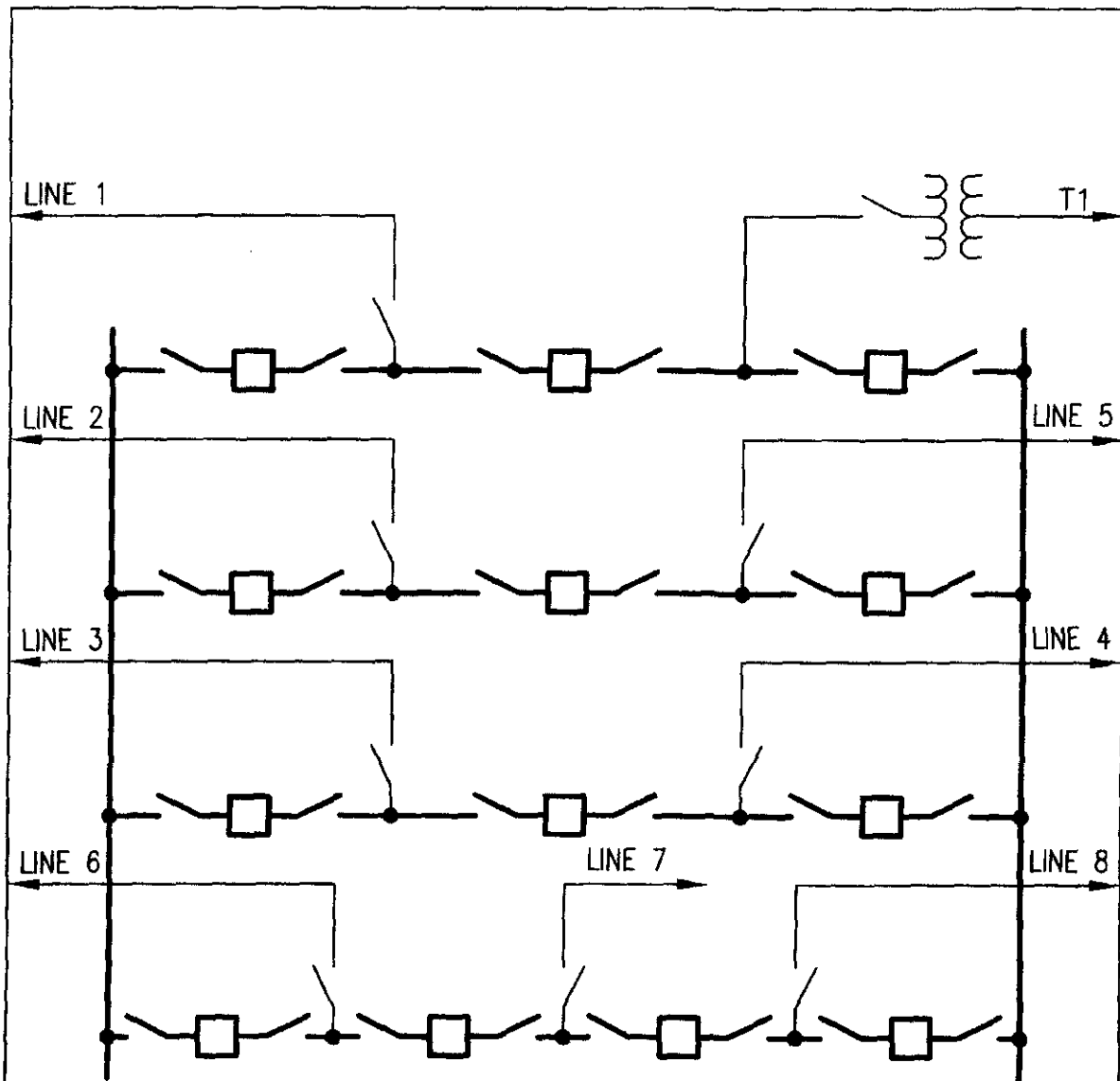

FIGURE 13 :COMBINATION BREAKER-AND-A-HALF AND
BREAKER-AND-A-THIRD BUS ARRANGEMENT

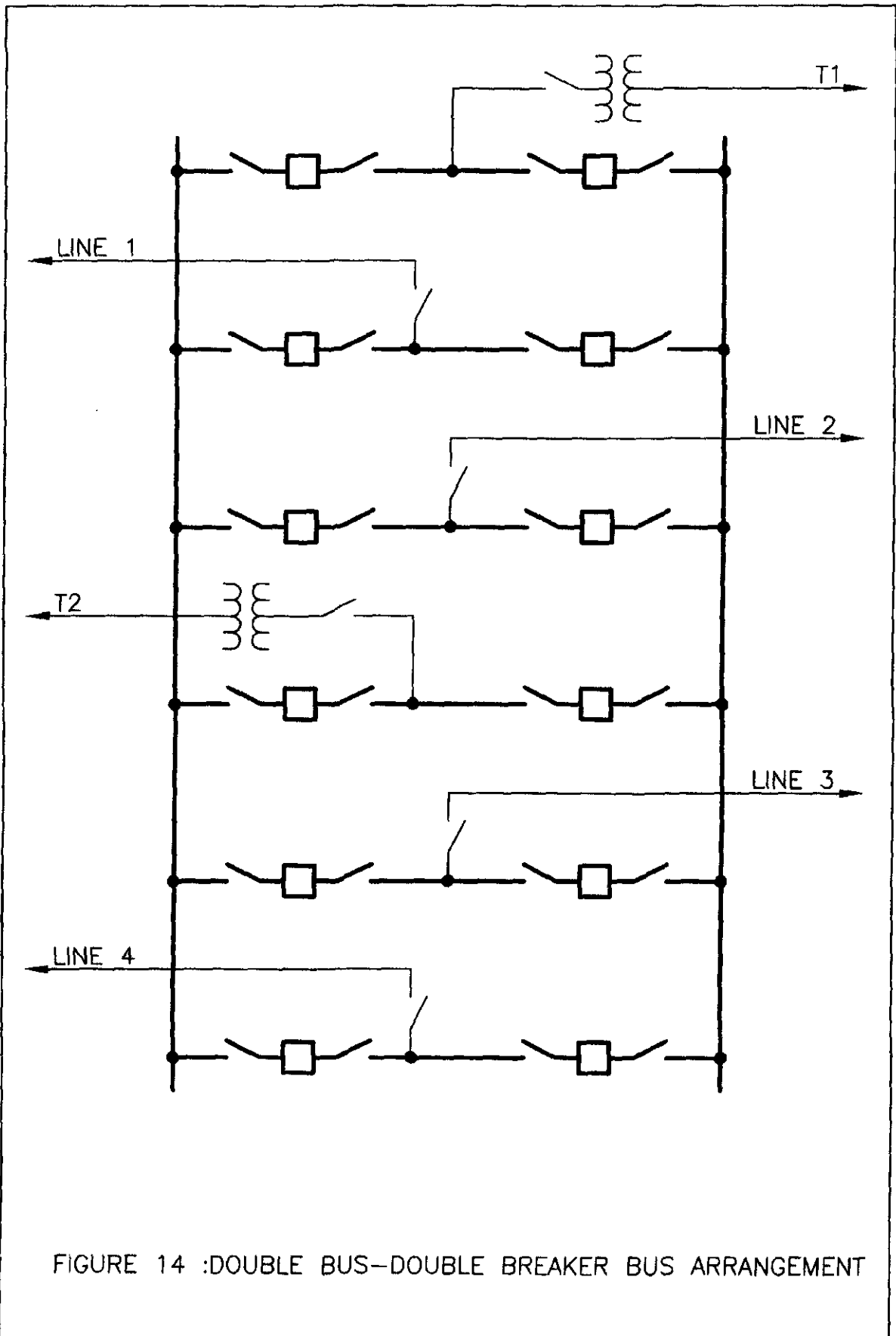

FIGURE 14 :DOUBLE BUS-DOUBLE BREAKER BUS ARRANGEMENT

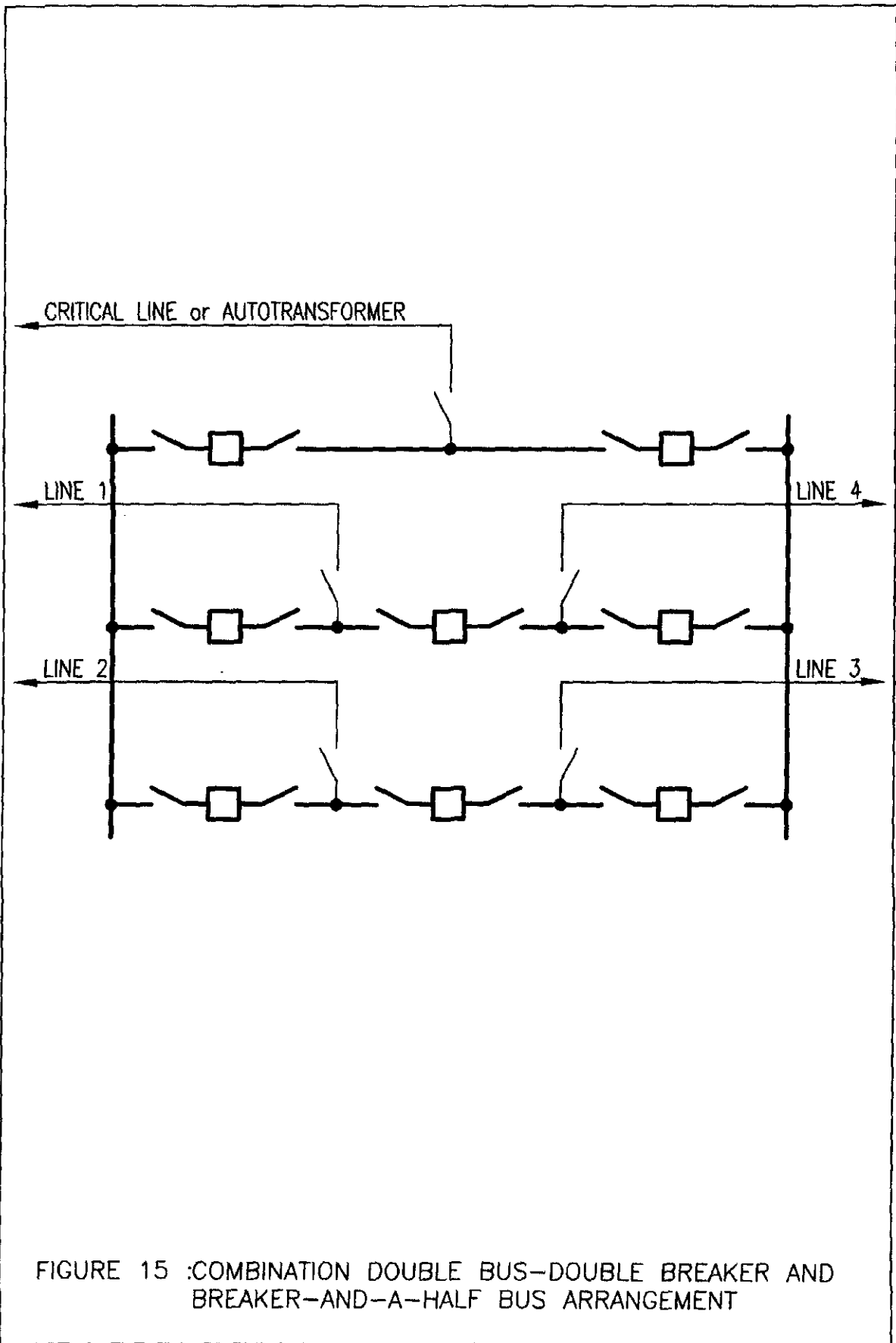

FIGURE 15 :COMBINATION DOUBLE BUS-DOUBLE BREAKER AND BREAKER-AND-A-HALF BUS ARRANGEMENT

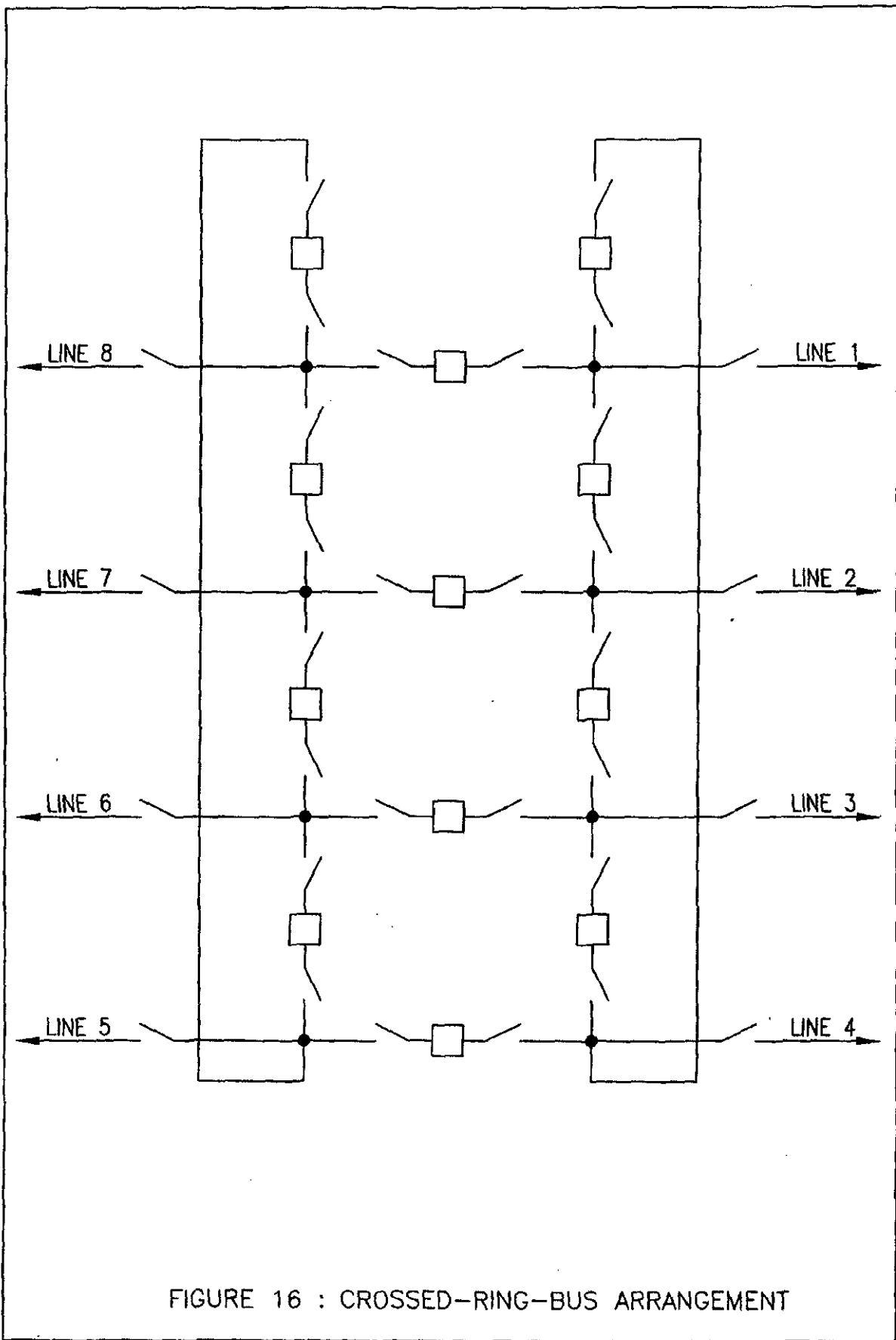

FIGURE 16 : CROSSED-RING-BUS ARRANGEMENT

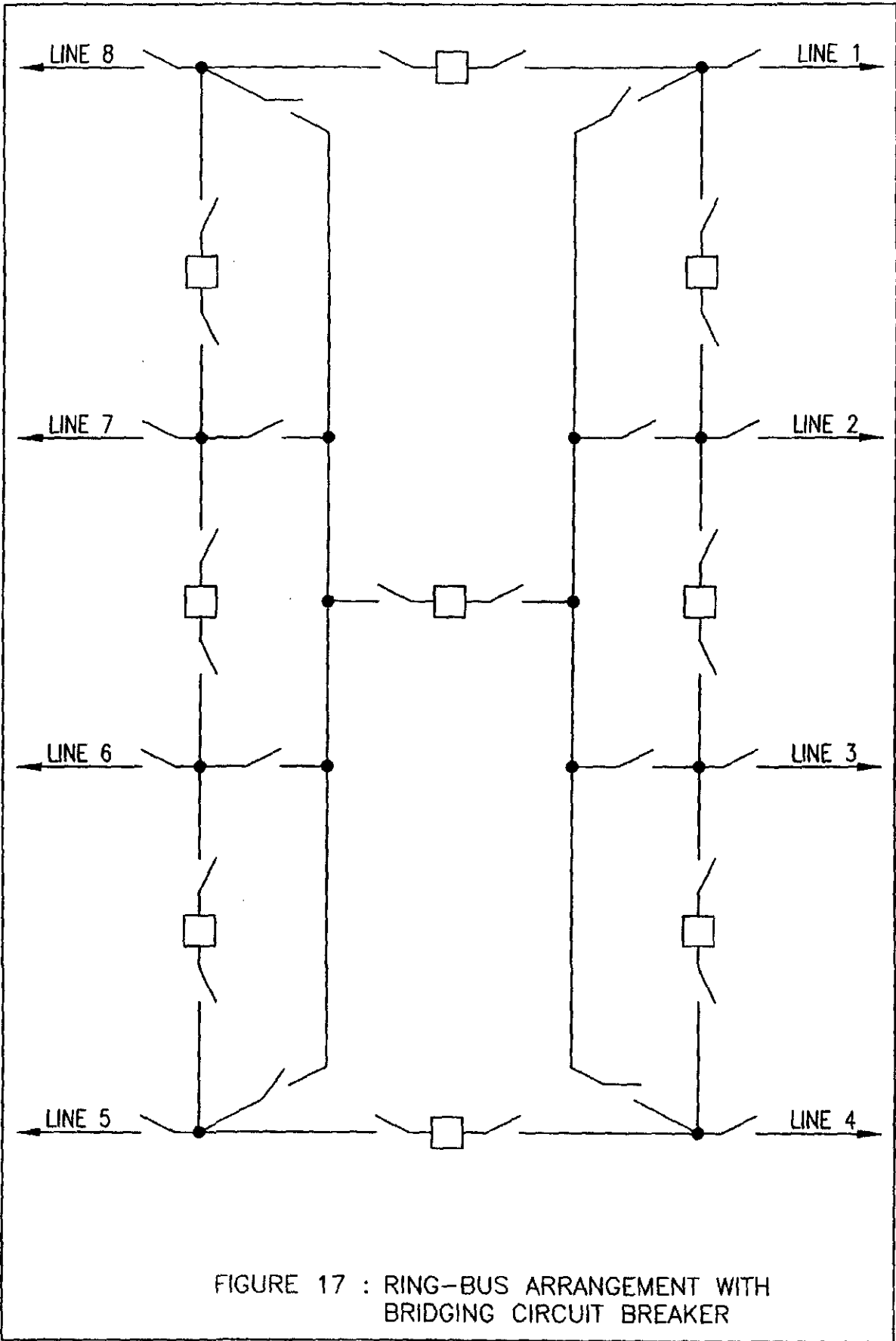

FIGURE 17 : RING-BUS ARRANGEMENT WITH BRIDGING CIRCUIT BREAKER